

MiSight 1 Day (omafilcon A) Soft (Hydrophilic) Contact Lenses For Daily Wear

IMPORTANT: Please read carefully and keep this information for future use. This package insert is intended for the eye care practitioner, but should be made available to patients upon request. The eye care practitioner should provide the patient with the patient instructions that pertain to the patient's prescribed lens.

SYMBOLS KEY

The following symbols may appear on the label or carton.

SYMBOL	DEFINITION	Reference
	Caution: Federal (USA) law restricts this device to sale by or on the order of a licensed practitioner	81 FR 38911
	Caution / See Instructions for Wearers	BS EN ISO 15223-1 Table 1, Symbol 5.4.4
	Use by Date (expiration date)	BS EN ISO 15223-1 Table 1, Symbol 5.1.4
	Batch Code	BS EN ISO 15223-1 Table 1, Symbol 5.1.5
	Sterile using Steam Heat	BS EN ISO 15223-1 Table 1, Symbol 5.2.5
	Manufacturer	BS EN ISO 15223-1 Table 1, Symbol 5.1.1
	Authorized representative in the European Community	BS EN ISO 15223-1 Table 1, Symbol 5.1.2
	Do not use if package is damaged	BS EN ISO 15223-1 Table 1, Symbol 5.2.8
	Consult instructions for use / consult electronic instructions for use	BS EN ISO 15223-1 Table 1, Symbol 5.4.3
	Do not re-use	BS EN ISO 15223-1 Table 1, Symbol 5.4.2
	Date of manufacture	BS EN ISO 15223-1 Table 1, Symbol 5.1.3

CAUTION: FEDERAL LAW RESTRICTS THIS DEVICE TO SALE BY OR ON THE ORDER OF A LICENSED PRACTITIONER.

DESCRIPTION

MiSight (omafilcon A) daily wear single use contact lenses are made from a material containing 60% water and 40% omafilcon A, consisting of 2-hydroxy-ethylmethacrylate and 2-methacryloyloxyethyl phosphorycholine polymers cross-linked with ethyleneglycol dimethacrylate. The lens material has a permanently fixed tint using Vat Blue 6, which is added to make the lens more visible for handling.

MiSight daily wear single use contact lenses parameters:

- o Diameter: 13.00 mm to 15.5 mm
- o Basic Curve: 8.00 mm to 9.50 mm
- o Center Thickness: 0.08 mm to 0.14 mm (dependent on power)
- o Powers: -0.25D to -7.00D in 0.25 steps

The optic zone design is a concentric ring design with alternating vision correction zones and treatment zones (shaded in diagram). Zones 1 and 3 are vision correction zones and the label power of the contact lens. Zones 2 and 4 are treatment zones with 2 diopters of defocus to slow the progression of myopia.

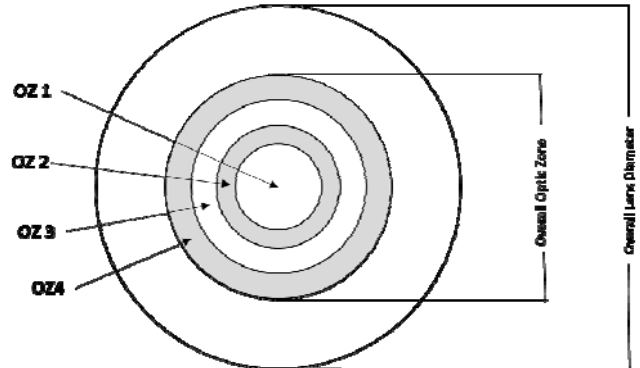

The physical/optical properties of the lens are:

- o Refractive Index: 1.395 ± 0.005
- o Light Transmittance: $> 90\%$
- o Water Content: $60\% \pm 2\%$
- o Oxygen Permeability: $25 \times 10^{-11} \text{ (cm}^2\text{/sec)(ml O}_2\text{/ml x mmHg)}$ (Polarographic FATT Method)

ACTIONS

When placed on the cornea in its hydrated state, the **MiSight** daily wear single use (omafilcon A) Soft (Hydrophilic) Contact Lens acts as a refracting medium to focus light rays on the retina and to simultaneously provide an optical stimulus to slow the progression of myopia.

INDICATIONS FOR USE

MiSight 1 Day (omafilcon A) Soft (Hydrophilic) Contact Lenses for Daily Wear are indicated for the correction of myopic ametropia and for slowing the progression of myopia in children with non-diseased eyes, who at the initiation of treatment are 8-12 years of age and have a refraction of -0.75 to -4.00 diopters (spherical equivalent) with ≤ 0.75 diopters of astigmatism. The lens is to be discarded after each removal.

CONTRAINDICATIONS

Do not use the **MiSight daily wear single use** lens when any of the following conditions exist:

- o Acute and subacute inflammation or infection of the anterior chamber of the eye.
- o Any eye disease, injury, or abnormality that affects the cornea, conjunctiva, or eyelids.
- o Severe insufficiency of lacrimal secretion (dry eyes).
- o Corneal hypoesthesia (reduced corneal sensitivity), if not aphakic.
- o Any systemic disease that may affect the eye or be exaggerated by wearing contact lenses.
- o Allergic reactions of ocular surfaces or adnexa that may be induced or exaggerated by wearing contact lenses or use of contact lens solutions.
- o Any active corneal infection (bacterial, fungal, or viral).
- o If eyes become red or irritated.
- o The patient is unable to follow lens handling and wear regimen or unable to obtain assistance to do so.

WARNINGS

Patients should be advised of the following warnings pertaining to contact lens wear:

- **PROBLEMS WITH CONTACT LENSES COULD RESULT IN SERIOUS INJURY TO THE EYE.** It is essential that patients follow their eye care practitioner's directions and all labeling instructions for proper use of lens. Eye problems, including corneal ulcers, can develop rapidly and lead to loss of vision. If a patient experiences eye discomfort, excessive tearing, vision changes, or redness of the eye, the patient should be instructed to immediately remove lenses and promptly contact his or her eyecare practitioner.
- **WATER ACTIVITY**
 - Do not expose the contact lenses to water while wearing them.
 - Water can harbor microorganisms that can lead to severe infection, vision loss or blindness. If the lenses have been submersed when swimming in pools, lakes, or oceans, discard them and replace them with a new pair.
 - Ask eye care practitioner (professional) for recommendations about wearing the lenses during any activity involving water.
- **EYE PROBLEMS, INCLUDING CORNEAL ULCERS, CAN DEVELOP RAPIDLY AND LEAD TO LOSS OF VISION; IF THE FOLLOWING IS EXPERIENCED:**
 - Eye Discomfort,
 - Excessive Tearing,
 - Vision Changes;
 - Loss of Vision,
 - Eye Redness
 - Or Other Eye Problems

PATIENTS SHOULD BE INSTRUCTED TO IMMEDIATELY REMOVE THE LENSES, AND PROMPTLY CONTACT THE EYE CARE PRACTITIONER.

- Daily wear lenses are not indicated for overnight wear, and patients should be instructed not to wear lenses while sleeping. Clinical studies have shown that risk of serious adverse reactions is increased when these lenses are worn overnight.
- Single Use, Daily Disposable lenses are not intended for cleaning or re-use, and on removal should be discarded and a fresh pair used each day.
- Studies have shown that contact lens wearers who are smokers have a higher incidence of adverse reactions than nonsmokers.
- MiSight lenses provide an optical correction that simultaneously presents one image "in-focus" and a second image "out-of-focus." Under certain circumstances (such as low light levels), this optical design can cause the following visual symptoms for some patients:
 - Reduced image contrast;
 - A ghost image (double image, with a mild second image seen);
 - Halos around bright lights; and glare around lights.

Not all patients function equally well with this type of correction. This type of correction can create a vision compromise that may cause difficulties with certain visually-demanding tasks. Patients should exercise extra care if performing potentially hazardous activities.

PRECAUTIONS

Special Precautions for Eye Care Practitioners

- When selecting an appropriate lens design and parameters, the eye care practitioner should consider all characteristics of the lens that can affect lens performance and ocular health, including oxygen permeability, wettability, central and peripheral thickness, and optic zone diameter.
- The potential impact of these factors on the patient's ocular health should be carefully weighed against the patient's need for refractive correction; therefore, the continuing ocular health of the patient and lens performance on the eye should be carefully monitored by the prescribing eye care practitioner.
- Fluorescein, a yellow dye, should not be used while the lenses are on the eyes. The lenses absorb the dye and become discolored. Whenever fluorescein is used in the eyes, the eyes should be flushed with a sterile saline solution that is recommended for in-eye use.
- Before leaving the eye care practitioner's office, the patient should be able to promptly remove the lenses or should have someone else available who can remove the lenses for him or her.
- Eye care practitioners should instruct the patient to remove the lenses immediately if the eye becomes red or irritated.

Eye care practitioners should carefully instruct patients about the following safety precautions:

- Lenses prescribed on a daily wear single use wearing schedule should always be discarded when removed at the end of the wearing day.
- The compatibility of the lens with lens care regimens has not been evaluated.
- Do not use saliva or anything other than the recommended solutions for lubricating or wetting lenses.
- If the lens sticks (stops moving) on the eye, follow the recommended directions on Care for a Sticking Lens. The lens should move freely on the eye for the continued health of the eye. If non-movement of the lens continues, the patient should be instructed to **immediately** consult his or her eye care practitioner.
- Always wash and rinse hands before handling lenses. Do not get cosmetics, lotions, soaps, creams, deodorant, or sprays in the eyes or on the lenses. It is best to put on lenses before putting on makeup. Water-based cosmetics are less likely to damage lenses than oil-based products.
- Do not touch the contact lenses with the finger or hands if the hands are not free of foreign materials, as lens damage may occur.
- Carefully follow the handling, insertion, removal, and wearing instructions in the Patient Instructions for MiSight contact lenses and those prescribed by the eye care practitioner.
- Never wear lenses beyond the period recommended by the eye care practitioner.
- If aerosol products such as hairspray are used while wearing lenses, exercise caution and keep eyes closed until the spray has settled.
- Always handle lenses gently and avoid dropping them.
- Avoid all harmful or irritating vapors and fumes while wearing lenses.
- Ask the eye care practitioner about wearing the lenses during sporting activities.
- Inform the doctor (health care practitioner) about being a contact lens wearer.
- Never use tweezers or other tools to remove lenses from the lens container unless specifically indicated for that use. Pour the lens into your hand.
- Do not touch the lens with fingernails.
- Always contact the eye care practitioner before using any medicine in the eyes.
- Always inform the employer of being a contact lens wearer. Some jobs may require use of eye protection equipment or may require that the patient not wear contact lenses.
- As with any contact lens, follow-up visits are necessary to assure the continuing health of the patient's eyes. The patient should be instructed as to a recommended follow-up schedule.
- Although the clinical study demonstrated decreased progression in

myopia during its three-year duration with the MiSight lenses, any potential benefits beyond the three-year study, specifically with regard to the further slowing of myopic progression or the prevention of future retinal disease have not been determined.

- Several inclusion/exclusion criteria restricted participating subjects in the MiSight pivotal study to those in whom contact lens wear might pose greater risks, and to those with characteristics that might reduce the effectiveness of the treatment. Thus, the safety and effectiveness of the use of the device in these types of patients is not known. Patients with the following characteristics were not studied:
 - Best corrected visual/acuity worse than 20/25;
 - Younger than 8 or older than age 12 at initiation of treatment (no patient was seen in any year of the study who was older than age 15);
 - Spherical equivalent refractive error lower than -0.75 D or higher than -4.00 D at initiation of treatment
 - Astigmatism > 0.75 D at initiation of treatment
 - Anisometropia \geq 1.00 D at initiation of treatment
 - Exhibiting poor personal hygiene;
 - Born earlier than 30 weeks or weighed less than 1500g (3.3lb) at birth;
 - Regularly using of ocular medications (prescription or over-the-counter), artificial tears, or wetting agents;
 - Currently using systemic medications which may significantly affect contact lens wear, tear film production, pupil size, accommodation or refractive state. Such as, but not limited to: long term use of nasal decongestants (for example, pseudoephedrine, phenylephrine), antihistamines (for example, chlorpheniramine, diphenhydramine), prednisolone or Ritalin (methylphenidate).
 - With a history of corneal hypoesthesia (reduced corneal sensitivity), corneal ulcer, corneal infiltrates, ocular viral or fungal infections or other recurrent ocular infections.
 - Showing strabismus by cover test;
 - Having known ocular or systemic disease such as, but not limited to: anterior uveitis or iritis, episcleritis or scleritis, glaucoma, Sjögren's syndrome, lupus erythematosus, scleroderma, or diabetes;
 - Having known ocular or systemic or neuro- developmental conditions that could influence refractive development. Such as, but not limited to: persistent pupillary membrane, vitreous hemorrhage, cataract, corneal scarring, ptosis eyelid hemangiomas, Marfan's syndrome, Down's syndrome, Ehler's-Danlos syndrome, Stickler's syndrome, ocular albinism, retinopathy of prematurity;
 - Having keratoconus or an irregular cornea;
 - Showing biomicroscope findings that would contraindicate contact lens wear including, but not limited to: neovascularization; active anterior segment ocular disease, grade 3 or 4 abnormalities

ADVERSE REACTIONS

The patient should be informed that the following problems may occur when wearing contact lenses:

- Eyes stinging, burning, or itching (irritation), or other eye pain.
- Comfort is less than when the lens was first placed on the eye.
- Feeling that something is in the eye such as a foreign body or a scratched area.
- Excessive watering (tearing) of the eyes.
- Unusual eye secretions.
- Redness of the eyes.
- Reduced sharpness of vision (poor visual acuity).
- Sensitivity to light (photophobia).
- Dry eyes.

When any of the above problems occur, it may be a symptom of a serious condition such as corneal infection, corneal ulcer/opacity, infiltrative keratitis, corneal abrasion, corneal edema, neovascularization, or iritis. Some of these adverse events can cause permanent or temporary loss of vision.

If the patient notices any of the above, he or she should be instructed to:

- **Immediately remove the lenses.**
- If the discomfort or the problem stops, then look closely at the lens. If the lens is in some way damaged, **do not** put the lens back on the eye. If the problem continues, **do not** put the lens back on your eye; **immediately remove the lenses and consult the eye care practitioner.**

Other adverse effects potentially associated with daily wear contact lenses are: conjunctivitis, giant papillary conjunctivitis, blepharitis/meibomianitis, tarsal hyperemia/lid irritation, hyperemia of the bulbar conjunctiva, superficial punctate keratitis, subconjunctival hemorrhage, and mild pannus.

Due to the optical design of the MiSight lenses, containing two focal points, under certain circumstances (e.g., low light conditions) some wearers may notice reduced image contrast, halos or glare around bright lights or ghost images (double images).

CLINICAL STUDIES

Two clinical studies were completed to support FDA approval. These studies are summarized here:

**MISIGHT RANDOMIZED, CONTROLLED STUDY
Study Description:**

The MiSight (omafilcon a) study was a three-year parallel-group, randomized, controlled, double-masked clinical trial at four investigative sites. The control lens was Proclear 1 Day (omafilcon A). The lenses were identical in overall geometry with the exception of the front surface optical zone. The primary effectiveness endpoints were the change in cycloplegic spherical equivalent refractive error and the change in axial length over three years. The primary safety endpoint was the comparison of biomicroscopy findings and adverse events.

One-hundred-forty-four (144) subjects met the eligibility criteria and were randomized to the MiSight or Control group. Subjects were eligible for the study if they were 8 to 12 years of age inclusive at the baseline examination and had cycloplegic Spherical Equivalent Refractive Error (SERE) between -0.75 and -4.00 D inclusive, astigmatism ≤ -0.75 D and anisometropia < 1.00 D. Sixty-five subjects were dispensed the MiSight lens and 70 subjects were dispensed the control soft contact lens.

The randomized groups were comparable in terms of age, gender, ethnicity, baseline refractive error and axial length. The average age was 10.1 year-of-age in each group. The mean baseline cycloplegic spherical equivalent refractive error was -2.02 D in the MiSight group and -2.19 D in the Control group. The mean baseline axial length was 24.4 mm in the MiSight group and 24.5 mm in the Control group. Fifty-three (53) MiSight subjects and 56 Control subjects completed the 3- year study.

Effectiveness Endpoint

The primary statistical analyses for effectiveness were the mean changes in cycloplegic SERE and axial length. These were compared between the two groups using a linear mixed model, statistically adjusting for possible baseline imbalances in age, sex, ethnicity, or baseline refractive error. The least-squares-mean cycloplegic refractive error and axial length change over 3-years are shown below.

**3-Year Myopic Progression from Baseline
(LS Mean - All Available Eyes)**

	LS Mean	Std. Err	95% Confidence Interval	p-value
Refractive Error (SERE)				
MiSight	-0.65 D	0.07	-0.50 to -0.79	
Control	-1.31 D	0.08	-1.16 to -1.46	
Difference	0.67 D	0.09	0.49 to 0.84	<0.0001
Axial Length				
MiSight	0.34 mm	0.03	0.27 to 0.41	
Control	0.62 mm	0.03	0.56 to 0.69	
Difference	-0.28 mm	0.04	-0.20 to -0.36	<0.0001

The difference between the groups for both refractive error and axial length were statistically significant. The change in axial length was highly correlated with the change in refractive error.

The mean contact lens visual acuity was 20/20 or better for the MiSight group and the Control group at all visits over three years. The mean wearing times were 11-12 hours per day for at least 6 days per week and were similar for both groups.

Additional Analysis

Additional analyses were performed to further characterize the myopia progression in the two groups. The table below shows the percentage of subjects in each group at various levels of myopic increase.

**3-Year Cycloplegic SERE Change from Baseline
(All Available Eyes)**

Change from Baseline	Control (N=112 eyes)		MiSight (N=104 eyes)	
	n	%	n	%
-0.25 D or less	4	3.6%	43	41.3%
-0.50 D or less	11	9.8%	57	54.8%
-0.75 D or less	30	26.8%	70	67.3%
-1.00 D or less	43	38.4%	85	81.7%
More than -1.00D	69	61.6%	19	18.3%

% = n/N(100)

The year-by-year change in refractive error is shown in the following table. This table shows the unadjusted mean change for all eyes with data within the interval as well as stratification by age at enrollment. In all age groups, the first year of use showed the greatest difference in myopia progression between test and control groups with continued accumulation of effect over the 3-year study period.

**Year-to-Year Cycloplegic SERE Change
(Unadjusted Mean - All Available Eyes)**

	0-12M		12-24M		24-36M		0-36M	
	P1D	MS	P1D	MS	P1D	MS	P1D	MS
All Eyes								
N	120	116	118	108	112	102	112	104
Mean (D)	-0.58	-0.18	-0.33	-0.19	-0.30	-0.17	-1.24	-0.51
Difference (D)	+0.40		+0.15		+0.13		+0.73	
% Control	69%		45%		44%		59%	
8 years old at Enrollment								
N	20	8	20	8	20	8	20	8
Mean (D)	-0.70	-0.38	-0.30	-0.17	-0.39	-0.21	-1.39	-0.76
Difference (D)	+0.32		+0.14		+0.18		+0.64	
9 years old at Enrollment								
N	28	34	28	30	28	28	28	30
Mean (D)	-0.77	-0.26	-0.25	-0.25	-0.29	-0.23	-1.44	-0.72
Difference (D)	+0.51		0.00		+0.06		+0.71	
10 years old at Enrollment								
N	14	24	14	22	14	22	14	22
Mean (D)	-0.57	-0.13	-0.23	-0.17	-0.32	-0.13	-1.12	-0.39
Difference (D)	+0.44		+0.07		+0.19		+0.73	
11 years old at Enrollment								
N	30	26	28	24	26	24	26	24
Mean (D)	-0.51	-0.18	-0.45	-0.21	-0.26	-0.09	-1.20	-0.47
Difference (D)	+0.33		+0.24		+0.17		+0.73	
12 years old at Enrollment								
N	28	24	28	24	24	20	24	20
Mean (D)	-0.40	-0.06	-0.38	-0.11	-0.25	-0.18	-0.98	-0.28
Difference (D)	+0.35		+0.27		+0.06		+0.71	

% Control=Difference/P1D Mean (D) X100

The year-to-year change in axial length showed a pattern of progression similar to that of the refractive error progression. The following table shows the unadjusted mean change for all eyes with data within the interval.

Year-to-Year Axial Length Change

(Unadjusted Mean - All Available Eyes)

	0-12M		12-24M		24-36M		0-36M	
	P1D	MS	P1D	MS	P1D	MS	P1D	MS
All Eyes								
N	120	116	118	108	112	102	112	104
Mean (mm)	+0.24	+0.09	+0.21	+0.12	+0.17	+0.11	+0.62	+0.30
Difference (mm)	-0.15		-0.10		-0.06		-0.32	
% Control	63%		46%		34%		52%	

% Control = Difference/P1D Mean (mm) X100

Study Cohort

Age @ Fit	Subjects n (%)
8 years	54 (7%)
9 years	107 (14%)
10 years	162 (21%)
11 years	220 (28%)
12 years	239 (30%)
Total	782 (100%)

Safety Endpoint

The incidence of adverse events was similar between the MiSight and Control groups. This would be expected due to the similarity of lens geometry and lens material. None of the ocular adverse events were considered as Serious Adverse Events. The table below shows the adverse events for all eyes randomized to wear lenses.

Eyes with Adverse Events (Eyes of All Dispensed Subjects)
(All Available Eyes)

	Control (N = 140 eyes)		MiSight (N = 130 eyes)	
	n	%	n	%
Infiltrative Keratitis	3	2.1	1	0.8
Corneal opacity	1	0.7	0	0.0
Conjunctivitis	3	2.1	2	1.5
Blepharitis / Meibomianitis	0	0.0	4	3.1
Tarsal hyperemia / Lid irritation	1	0.7	3	2.3
Foreign body	0	0.0	1	0.8
Superficial Punctate Keratitis	1	0.7	3	2.3
Subconjunctival hemorrhage	1	0.7	1	0.8
Mild pannus	0	0.0	1	0.8
Other: headache, asthenopia, dryness	2	1.4	2	1.5

% = n/N(100)

There were 2 cases of temporary reduction in visual acuity of two lines measured at one visit only. These were not related to any observation of significant eye problems and resolved without treatment.

Overall, there were very few visits with Grade 2 or greater biomicroscopy findings. There were no Grade 4 findings and very few visits with Grade 3 findings (0.4% MiSight; 0.1% Control).

RETROSPECTIVE COHORT STUDY OF SOFT LENS WEAR IN CHILDREN

Study Description:

A retrospective cohort study was performed to estimate a rate of microbial keratitis and other adverse events in conventional daily wear soft contact lenses in children initially fit between the ages of 8-12 years of age.

Data was obtained by a medical record audit of children fitted with commercial soft contact lens in seven US eye care practices. The lenses were various commercially available soft contact lenses. MiSight lenses were not included in this audit as they were not yet available in the US.

Clinical records from 782 children fit in eye care practices and followed for an average of 2.7 years-of-wear were collected and evaluated. In total, this represents 2,134 patient-years of observation of children wearing soft contact lenses. Current status (last visit within 9 months) was obtained for 93% of the patients. The age distribution of the cohort studied is shown below.

Part Number: PI01173

Revision: A

Redacted clinical records were reviewed by an independent expert adjudication committee and a consensus diagnosis was determined for each case. Two cases were adjudicated as microbial keratitis from the eye care practices. Both cases resolved with 20/20 vision and the patients returned to contact lens wear. A mild scar remained in one case.

Based upon this data, the estimated annualized rate of microbial keratitis is estimated at 2/2134 patient-years (0.094%) or 9.4/10,000 patient-years (95% C.I = 2.3 to 37.7).

Estimated Annual Incidence of Microbial Keratitis in Soft Contact Lenses (Total Patient-Years of Observation = 2134)

	Number of Cases	Annualized Rate/10,000	2-sided 95%CI
Microbial Keratitis	2	9.4	2.3 to 37.7

The rate of non-infectious infiltrative adverse events is summarized in the following table. Fourteen (14) non-infectious infiltrates were observed, four (4) of which were adjudicated as peripheral ulcers.

Estimated Annual Incidence of Non-infectious Infiltrative Events (Total Patient-Years of Observation = 2134)

Adverse Events	Number of Cases	Annualized Rate	2-sided 95%CI
All Non-infectious Infiltrative Events	14	0.66%	0.36 - 1.10%
Peripheral Ulcer	4	0.19%	0.05 - 0.50%

Limitations of this type of observational study may include selection bias, since there is no randomization to treatment; missing information, since medical records may not contain information pertinent to the study; and loss to follow-up, since patients may seek medical care at locations other than the participating eye care practice.

FITTING

Conventional methods of fitting contact lenses apply to all MiSight contact lenses. For a detailed description of the fitting techniques, refer to the MiSight Professional Fitting and Information Guide, copies of which are available from:

CooperVision, Inc.
711 North Road
Scottsville, New York 14546
1-800-341-2020
www.coopervision.com

WEARING SCHEDULE

For best results, it is recommended that the patient wears the lens for a minimum of 10 hours per day for at least 6 days per week. Daily wear lenses are not indicated for overnight wear, and patients should be instructed not to wear lenses while sleeping.

All MiSight lenses should be discarded and replaced with a new lens on a daily basis.

LENS CARE DIRECTIONS

The MiSight (omafilcon A) Soft (Hydrophilic) Contact Lenses are indicated for daily wear single use only. The lenses are to be discarded upon removal; therefore, no cleaning or disinfection is required.

For MiSight contact lenses prescribed for daily wear single use only: The Eye Care Professional should review with patients that no cleaning or disinfection is needed. Patients should always dispose of lenses when they are removed and have replacement lenses or spectacles available.

- The patient should always have a spare pair of lenses at all times.
- Always wash, rinse, and dry hands before handling contact lenses.
- Do not use saliva. Do not put lenses in the mouth.
- Eye care practitioners may recommend a lubricating/rewetting solution which can be used to wet (lubricate) lenses while they are being worn to make them more comfortable.

CARE FOR A DRIED OUT (DEHYDRATED) LENS

If any MiSight lens is exposed to air while off the eye, it may become dry and brittle. In this event, simply dispose of the lens and replace with a fresh one.

CARE FOR A STICKING (NONMOVING) LENS

If the lens sticks (stops moving or cannot be removed), the patient should be instructed to apply 2 to 3 drops of the recommended lubricating or rewetting solution directly to the eye and wait until the lens begins to move freely on the eye before removing it. If non-movement of the lens continues more than 5 minutes, the patient should immediately consult the eye care practitioner.

EMERGENCIES

The patient should be informed that if chemicals of any kind (household products, gardening solutions, laboratory chemicals, etc.) are splashed into the eyes, the patient should: FLUSH THE EYES IMMEDIATELY WITH TAP WATER AND IMMEDIATELY CONTACT THE EYE CARE PRACTITIONER OR VISIT A HOSPITAL EMERGENCY ROOM WITHOUT DELAY.

HOW SUPPLIED

Each lens is supplied sterile in a blister containing buffered isotonic saline solution. The blister is labeled with the base curve, diameter, dioptric power, manufacturing lot number, and expiration date of the lens.

DO NOT USE IF THE MISIGHT LENS IS BROKEN OR THE SEAL HAS BEEN DAMAGED

REPORTING OF ADVERSE REACTIONS

All serious adverse experiences and adverse reactions observed in patients wearing any MiSight contact lens or experienced with the lenses should be reported to:



Attn: Product Services
711 North Road
Scottsville, New York 14546
(800) 341-2020
www.coopervision.com